

## Heat Flux Estimation of the Mars Science Laboratory Entry, Decent and Landing Instrumentation (MEDLI)

Engineers: Eric Johnson, Caleb Prather, John Wilkins  
Advisor: Robert L. McMasters



**Figure 1:** MSL heat shield made with PICA.

The Mars Science Laboratory (MSL) entry vehicle (EV) successfully entered the Mars atmosphere and landed the Curiosity rover safely on the surface of the planet in Gale Crater on August 6, 2012. The vehicle carried the MSL Entry, Decent, and Landing (EDL) Instrumentation (MEDLI). Of the three major subsystems, the MEDLI Integrated Sensor Plugs (MISP) enabled temperature measurements to be recorded at varying depths within the thermal protection system (TPS) throughout the entry and decent phases. Four Type-K thermocouples, plus an isotherm sensor, were used in making these measurements.

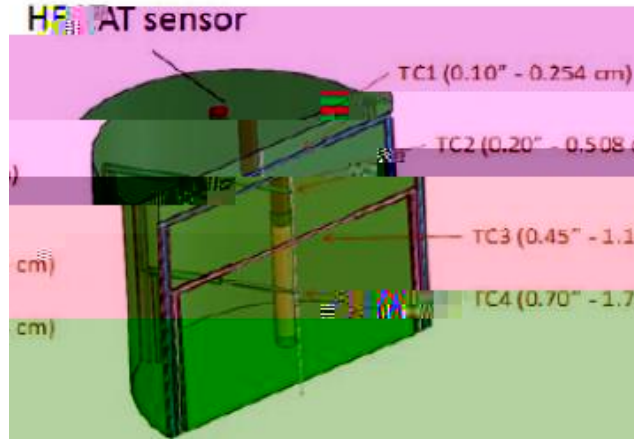

Figure 2: X-ray image of MISF.

The objective of this study was to estimate the heat fluxes experienced on the heat shield by using the measured temperatures. The first phase of this project was to utilize the commercial software Inverse Heat Conduction Problem 1-D (IHCP1D) developed by Beck Engineering. This technique utilizes various future time steps to estimate time-varying heating from in-depth temperature measurements. The second phase of this project was to develop a Matlab code utilizing the same technique as IHCP1D. The Matlab code provided a way for future studies to quantify the effects of surface ablation on the surface of the heat shield.

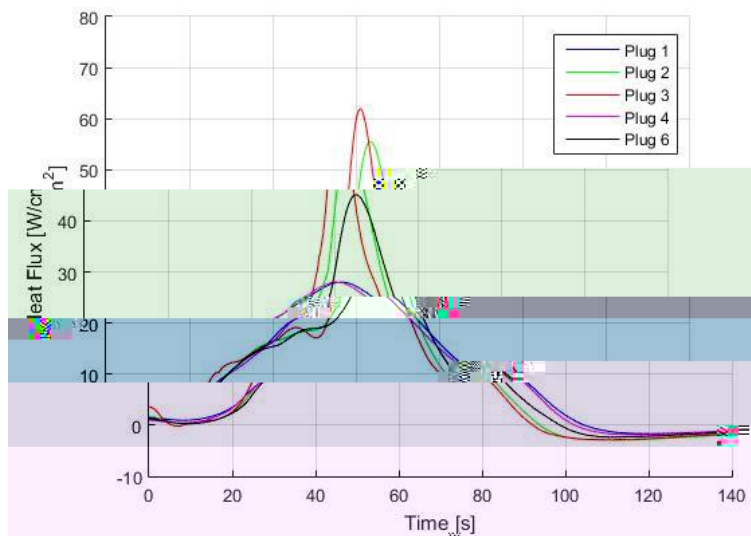

Figure 3: Heat flux estimation at the surface of various plugs